

PIUSI[®]

*Fluid Handling
Innovation*

DELPHIN

**PRO AC
IBC AC
PRO_X AC**



Installation, use and maintenance

EN

**MADE
IN
ITALY**

BULLETIN MO502A EN _00

ENGLISH

BULLETIN MO502A EN

1 INDEX

2	Conformity	4
	2.1 EC Declaration of conformity	4
	2.2 Declaration of compatibility	4
3	General precautions	5
4	Safety instructions	5
	4.1 Safety warnings	6
	4.2 First aid measures	6
	4.3 General safety norms	7
5	Distribution system packaging	7
	5.1 Contents of the packaging	7
	5.2 Delphin composition	8
6	Machine and manufacturer identification	8
	6.1 Plates positions	9
7	Technical characteristics	10
8	Intended use	10
9	Characteristics of the products handled	11
10	Installation	11
11	Assembling	11
12	Operation and use	12
	12.1 Display	13
	12.2 Flow rate adjustment	16
	12.3 Phases of delivery	17
13	System customization	18
	13.1 Users buttons	18
	13.2 Operating modes	18
	13.3 Daily use	18
	13.4 Dispensing in normal mode	19
	13.5 Partial reset (normal mode)	19
	13.6 Resetting the reset total	20
	13.7 Dispensing with flow rate mode display	20
	13.7.1 Partial reset (flow rate mode)	21
	13.8 Calibration	21
	13.8.1 Definitions	21
	13.8.2 Calibration mode	22
	13.8.3 Display and restoring k-factor	22
	13.8.4 Direct modification of k-factor	23
	13.9 Meter configuration	25
14	Leaving the system unused for long periods of time	26
15	Washing the dispensing system	26
16	Maintenance	27
17	Troubleshooting	28
18	Scrapping and disposal	29

2 CONFORMITY

2.1 EC DECLARATION OF CONFORMITY

The undersigned: **PIUSI S.p.A**
Via Pacinotti 16/A - z.i. Rangavino
46029 Suzzara - (MN) - Italy

DECLARES

on its own responsibility, that the machine described below:

Description: Dispenser AD-Blue® for cars.

Model: **Delphin PRO AC - Delphin PRO-X AC - Delphin IBC AC**

Serial number: see the Lot Number on the EC plate stamped on the product.

Year of construction: see the production year on the EC plate stamped on the product.

is in compliance with the legislative regulations which transpose directives:

- Machinery Directive 2006/42/EC

- Electromagnetic Compatibility Directive 2014/30/EC

Documents are made available to the appropriate authority on request at Piusi S.p.A. Alternatively, it can be requested writing to: e-mail: doc_tec@piusi.com

The person in charge of writing both the technical file and the conformity statement is Otto Varini as the legal representative.



Otto Varini
The legal representative

Suzzara 01/01/2019

2.2 DECLARATION OF COMPATIBILITY

The undersigned: **PIUSI S.p.A**
Via Pacinotti 16/A - z.i. Rangavino
46029 Suzzara - (MN) - Italy

DECLARES

That DELPHIN components in direct contact with the liquids handled, have been tested in conformity with the following directives

ISO22241-1 : 2006 (quality standard)

Diesel engines -- NOx reduction agent AUS 32 -- Part 1: Quality requirements and have been tested with the requirements of the following norm

ISO22241-2 : 2006 (quality standard)

Diesel engines -- NOx reduction agent AUS 32 -- Part 2: Test methods

The Adblue liquid , both before and after testing, resulted within the specified AUS32 (AdBlue) limit in conformance with ISO22241-2-2006 (as per Norm DIN V 70070)



Otto Varini
The legal representative

Suzzara 01/01/2019



3 GENERAL PRECAUTIONS

Warnings

To ensure operator safety and to protect the dispensing system from potential damage, workers must be fully acquainted with this instruction manual before attempting to operate the dispensing system.

Symbols used in the manual

The following symbols will be used throughout the manual to highlight safety information and precautions of particular importance:



ATTENTION

This symbol indicates safe working practices for operators and/or potentially exposed persons.



WARNING

This symbol indicates that there is risk of damage to the equipment and/or its components.



NOTE

This symbol indicates useful information.

Manual preservation

This manual should be complete and legible throughout. It should remain available to end users and specialist installation and maintenance technicians for consultation at any time.

Reproduction rights

All reproduction rights are reserved by Piusi S.p.A. The text cannot be reprinted without the written permission of Piusi S.p.A.

© Piusi S.p.A.

THIS MANUAL IS THE PROPERTY OF Piusi S.p.A.

ANY REPRODUCTION, EVEN PARTIAL, IS FORBIDDEN.

This manual belongs to Piusi S.p.A., which is the sole proprietor of all rights indicated by applicable laws, including, by way of example, laws on copyrights. All the rights deriving from such laws are reserved to Piusi S.p.A.: the reproduction, including partial, of this manual, its publication, change, transcription and notification to the public, transmission, including using remote communication media, placing at disposal of the public, distribution, marketing in any form, translation and/or processing, loan and any other activity reserved by the law to Piusi S.p.A..

4 SAFETY INSTRUCTIONS

Mains - preliminary checks before inst



ATTENTION

You must avoid any contact between the electrical power supply and the fluid that needs to be FILTERED.

Maintenance control

Before any checks or maintenance work are carried out, disconnect the power source.

ATTENTION FIRE AND EXPLOSION



To help prevent fire and explosion:

Use equipment only in well ventilated area.

Keep work area free of debris, including rags and spilled or open containers of solvent and gasoline.



Do not plug or unplug power cords or turn lights on or off when flammable fumes are present.

Ground all equipment in the work area.

Stop operation immediately if static sparking occurs or if you feel a shock. Do not use equipment until you identify and correct the problem.

Keep a working fire extinguisher in the work area.

When flammable fluids are present in the work area, such as gasoline and windshield wiper fluid, be aware that flammable fumes can ignite or explode.

ELECTRIC SHOCK



This equipment must be grounded. Improper grounding, setup or usage of the system can cause electric shock.

Electrocution or death



Turn off and disconnect power cord before servicing equipment.

Connect only to a grounded electrical outlets.

Use only 3 wire extension cords in accordance with local electrical codes. Extension cords should have a ground lead.

Ensure ground prongs are intact on power and extension cords.

Do not expose to rain. Store indoors.

Never touch the electric plug of socket with wet hands.

Do not turn the dispensing system on if the power connection cord or other important parts of the apparatus are damaged, such as the inlet outlet plumbing, dispensing nozzle or safety devices. Replace damaged components before operation.

Before each use check that the power connection cord and power plug are not damaged. If damaged, have power connection cord replaced before use by a qualified electrician.

The electrical connection between the plug and socket must be kept well away from water.

Unsuitable extension leads can be hazardous, in accordance with current regulations. Only extension cords that are labelled for outdoor use and have a sufficient conduction path should be used outdoors.

For safety reasons, we recommend that, in principle, the equipment be used only with a earth-leakage circuit breaker (max 30 mA).

Electrical connections must use ground fault circuit interrupter (GFCI).

Installation operations are carried out with the box open and accessible electrical contacts. All these operations have to be done with the unit isolated from the power supply to prevent electrical shock!

EQUIPMENT MISUSE



Misuse can cause death or serious injury

Do not operate the unit when fatigued or under the influence of drugs or alcohol.

Do not leave the work area while equipment is energized or under pressure.

Turn off all equipment when equipment is not in use.

Do not alter or modify equipment. Alterations or modifications may void agency approvals and create safety hazards.

Route hoses and cables away from traffic areas, sharp edges, moving parts, and hot surfaces.

Do not kink or over bend hoses or use hoses to pull equipment.

Keep children and animals away from work area.

Comply with all applicable safety regulations.

Toxic Fluid or Fumes Hazard



Read MSDSs to know the specific hazards of the fluids you are using.

Store hazardous fluid in approved containers, and dispose of it according to applicable guidelines.

4.1 SAFETY WARNINGS

ATTENTION Prohibitions



Lifting or transporting the system by way of the electric cables attached to it is strictly forbidden.

ATTENTION



It is strictly forbidden to support or transport the system using a suction or outlet pipe. In the event of a suspected contamination of the liquid in the car tank, sanitize the tank.







Do not use the Delphin Dispenser before recovery

4.2 FIRST AID MEASURES

Persons who have suffered electric shock

Disconnect the power source, or use a dry insulator to protect yourself while you move the injured person away from any electrical conductor. Avoid touching the injured person with your bare hands until he is far away from any conductor. Immediately call for help from qualified and trained personnel. Do not operate switches with wet hands.

4.3 GENERAL SAFETY NORMS

Personal protection equipment features	Wear personal protection equipment that is: <ul style="list-style-type: none"> • suitable to the operations to be performed; • resistant to the various cleaning products used.
Personal protection equipment to be worn	 Safety shoes;
	 Close-fitting clothes;
	 Protective gloves;
	 Safety glasses;
Other equipment	 Instructional manual
Protective gloves	Prolonged contact with the product may cause skin irritation; during delivery phases, always wear protective gloves.
DANGER	 <p>Never touch the plug or the socket with wet hands Do not switch the dispensing system on if the network connection cable or important parts of the apparatus are damaged, such as the inlet/outlet pipe, nozzle or safety devices. Replace the damaged pipe immediately. Before each use, check that the network connection cable and power plug are not damaged. Have the network connection cable replaced immediately by a qualified electrician.</p>



5 DISTRIBUTION SYSTEM PACKAGING

The dispensing system comes packed in a cardboard box bearing the following markings:

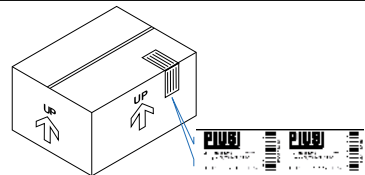
- an arrow indicating the TOP side;
- a label containing all the information relating to the equipment (model, weight, etc..).



5.1 CONTENTS OF THE PACKAGING

FOREWORD	In order to open the cardboard box, use scissors or a cutter, paying attention not to damage the distribution system or its components. Open the packaging and make sure it contains the following components provided:
NOTE	 <p>In case one or more herewith described components should not be in the box, contact Manufacturer's technical assistance service.</p>
ATTENTION	 <p>Make sure the plate data correspond to the desired ones. In case of anomalies, promptly contact the supplier, signalling the nature of the problems and, in case you should doubt the device safety, do not use it.</p>

5.2 DELPHIN COMPOSITION

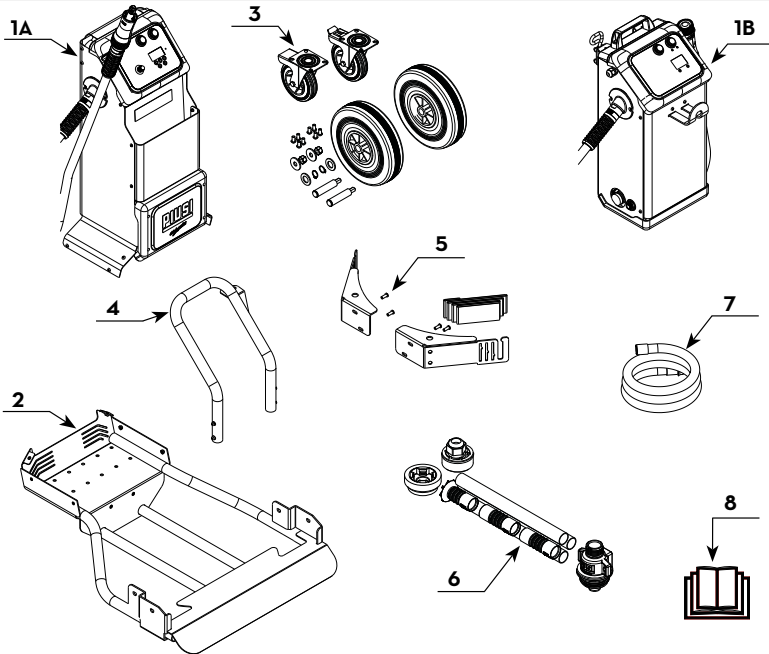

1A	MACHINE BODY FOR CART	5	BRACKETS + BAND
1B	MACHINE BODY FOR IBC	6	SUCTION KIT
2	SUPPORT CART	7	AIR RETURN HOSE
3	WHEEL KIT	8	INSTRUCTION MANUAL
4	HANDLE WITH BRACKET		

6 MACHINE AND MANUFACTURER IDENTIFICATION

The distribution system is provided with an identification marking located directly on the pump. This indicates the following information:

- model;
- technical data;
- lot number / Production year;
- use and maintenance handbook code.

ATTENTION



Before installing, always make sure the type of dispensing system is correct and suitable for the available power supply (Voltage/Frequency).



6.1 PLATES POSITIONS

On the distribution system there is an adhesive label that shows the operator the most important information. Make sure it stays on and that it does not deteriorate over time.

NOTE



Should this situation arise, please contact our support department and arrange to have the damaged or missing plates sent back and replaced where necessary.

Decals are the following ones:

1 - PPE plate

- protective gloves
- safety glasses
- close-fitting clothes
- see user and maintenance manual
- safety shoes



3 - CE plate with technical data

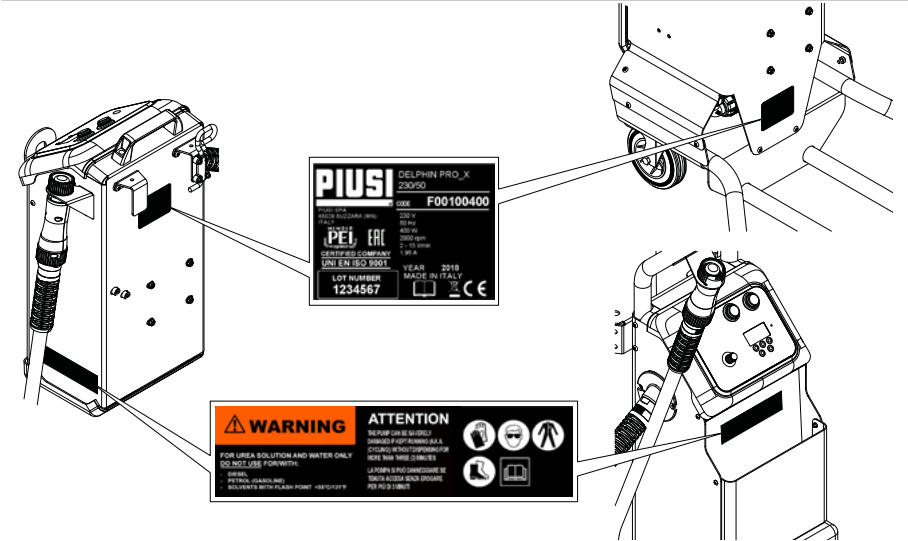

7 TECHNICAL CHARACTERISTICS

	DELPHIN AC PRO	DELPHIN AC /BC	DELPHIN AC PRO-X
Length (A)	800 mm	500 mm	800 mm
Depth (B)	860 mm	340 mm	860 mm
Height (C)	1200 mm	590 mm	1200 mm
Weight	43 Kg	23 Kg	43 Kg
Voltage	120 / 240 V	220 / 230 V	120 / 240 V
Frequency	50 / 60 Hz	50 / 60 Hz	50 / 60 Hz
Power rating	200 W	400 W	200 W
Absorption	1,1 A	1,95 A	1,1 A
Operating temperature	0 °C / + 40 °C	0 °C / + 40 °C	0 °C / + 40 °C
Flow Rate	min. 2 l/min. max 11 l/min.	min. 2 l/min. max 11 l/min.	min. 2 l/min. max 15 l/min.

8 INTENDED USE

Intended use

The dispensing system “Delphin” was designed and built for the distribution of the product called AdBlue®, D.E.F (Diesel Exhaust Fluid) or water.

Conditions of use

The distribution system “DELPHIN” must be used respecting the following conditions:

Max. temperature of dispensed product: +35 °C.

Min temperature of dispensed product: -11 °C.

Max. temperature of dispensed product permitted by materials: +40°C.

Voltage variation permitted: +/- 5%

Leq - Measured value of the average surface sound pressure level: [dB(A)] **64,6**

Operator station - Sound pressure value dB(A): **69,8**

Make sure the pump is working in its nominal operating range.

ATTENTION
Inflammable liquids and explosive atmosphere
ATTENTION



The system “DELPHIN” has not been designed to distribute diesel, gasoline, inflammable fluids having an explosion limit of $-55^{\circ}\text{C}/131^{\circ}\text{F}$, or to operate in places with potentially explosive atmosphere. Such use is therefore forbidden.

Unenvisaged use



It is strictly forbidden to use the system for purposes other than the ones indicated in point "Intended use".

Any other use different from the one for which the system has been conceived and described in this manual is considered "MISUSE". Therefore, the Manufacturer shall not be held responsible for any damage caused to people, animals or to the system itself.

9 CHARACTERISTICS OF THE PRODUCTS HANDLED

Products permitted

The "DELPHIN" dispensing system was designed and built to dispense a special liquid, made from an aqueous urea solution, known as AdBlue®/D.E.F., based on the ISO 22241 standard DELPHIN can also be used with water.

ATTENTION



Forbidden products

All products not listed in the "Intended Use" and "Treated Product Characteristics" paragraphs are to be considered not permitted, improper and therefore prohibited.

The Manufacturer shall not be held responsible for damages caused to people or things deriving from failure to meet such instructions.

10 INSTALLATION

Foreword

The "DELPHIN" dispensing system has been designed and arranged on a trolley for ease of use and delivery.

Personnel authorised to install the device

Installation must be performed exclusively by qualified and authorised staff. They must:

- properly install all the components necessary for the pump to function properly;

- only use accessories that have been supplied with the system.

ATTENTION



The use of accessories that are unsuitable and were not provided with the system is strictly prohibited. The Manufacturer shall not be held responsible for damages caused to people, things or to the environment deriving from failure to meet such instructions.

The distribution system DELPHIN is for professional use only.

The distribution system DELPHIN must be installed in a well lit place, in compliance with the norms in force.

The DELPHIN dispensing system has been specifically designed for use in a dry place. I

11 ASSEMBLING

DEPENDING ON THE MODEL, PROCEED WITH ASSEMBLY AS DETAILED IN THE MO431 SHEET SUPPLIED WITH THE STATION.

12 OPERATION AND USE

**Foreword
WARNING**



Directions on how to start and stop operation of the system are given below.
To remove any substance residue or foreign matters from the pipes, wash the system before putting it into operation.
To wash the system, follow the same dispensing procedures using demineralized or deionized water and eventually rinse with ADBLue®

ATTENTION



During operation the motor may be hot: be careful.

WARNING



For the proper functioning of the system, allow a 10-minute stop for every 20 minutes of dispensing.
We recommend that the pump remains switched off whenever the system is not in use.

ATTENTION



If ever the voltage is lagging, push the switch to the OFF position and return the nozzle to its rest position

FLUID LEAKS CAN DAMAGE OBJECTS AND INJURE PERSONS.

Strictly observe the maximum capacity limits indicated on the dataplate.

WARNING



Under no circumstances must the data on the dataplate, the closure and authentication seals be modified or removed.

Any tampering or removal will result in immediate nullification of the warranty and the manufacturer will not be held liable for any material or economic damage resulting thereof.

ATTENTION



Once the filling operation has been completed, replace the filler hose in its seat.

12.1 DISPLAY

DELPHIN PRO AC

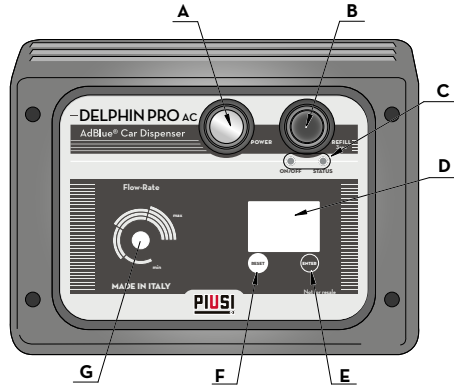

- A** **POWER** button: used to power the system.
- B** **REFILL** button: press for at least 5 seconds to start product delivery.
- C** red/green LED
- D** LCD Display
- E** ENTER button
- F** RESET button
- G** FLOW RATE ADJUSTMENT knob

LED INDICATOR TABLE

Power button	LED ON / OFF	LED STATUS	Meaning
Off	X	X	System off / Off
On	On	Off	Stand - by
On	Off	Fast Blink	Start of Activation sequence
On	Alternately blinking		Dispensing in progress
On	On	1 - 1-pulse blink	Dispensing ended - Time over
On	On	2 - 2-pulse blink	Selected flow rate too high
On	On	3 - 3-pulse blink	Overcurrent Malfunction
On	On	4 - 4-pulse blink	Meter malfunction

DELPHIN IBC AC

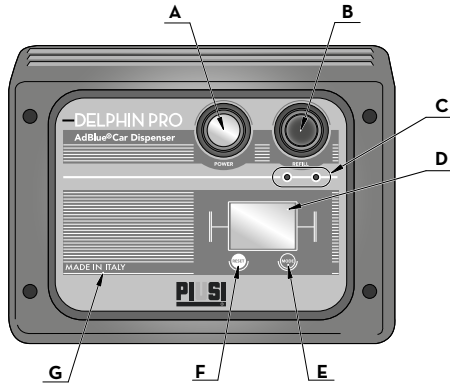

- A** **POWER** button: used to power the system.
- B** **REFILL** button: press for at least 5 seconds to start product delivery.
- C** red/green LED
- D** LCD Display
- E** MODE button
- F** RESET button
- G** Machine plate

LED INDICATOR TABLE

Power Button	Red LED	Green LED	Meaning
Off	X	X	System OFF
On	Off	Off	Stand By - Awaiting commands
On	Off	Fast Blink	Start-up sequence underway
On	Off	On	Dispensing
On	Off	Slow Blink	Filling completed - Full level
On	Fast Blink	Off	Filling completed - Time out
On	Slow Blink	Off	Selected flow rate - too high

DELPHIN PRO_X AC

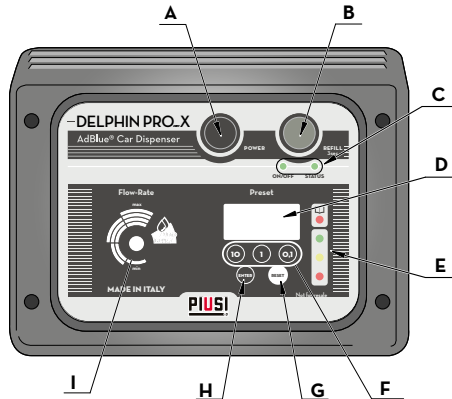

- A **POWER** button: used to power the system.
- B **REFILL** button: press for at least 3 seconds to start product delivery.
- C Red/green LED
- D LCD Display
- E Battery charging indicators LEDs
- F **PRESET** buttons
- G **RESET** button
- H **ENTER** button
- I **FLOW RATE / OPERATION** setting knob

ATTENTION  **If the labels are damaged, DO NOT use the machine and replace the label immediately.**

ATTENTION  **FOR THE OPERATION OF THE DELPHIN PRO-X MODEL, REFER TO THE QUICK GUIDE MO495**

12.2 FLOW RATE ADJUSTMENT

DELPHIN PRO AC FLOW RATE ADJUSTMENT

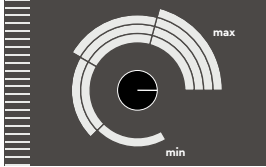

HIGH FLOW RATE position

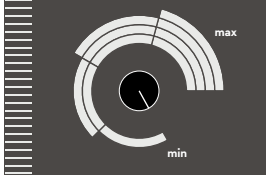

LOW FLOW RATE position

DELPHIN IBC AC FLOW RATE ADJUSTMENT



Lever in the
LOW FLOW RATE position

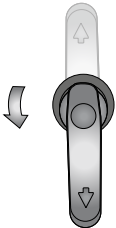

Lever in the
HIGH FLOW RATE position



NOTE



The adjustment lever is located on the side of the trolley.

ATTENTION



Use the flow rate adjustment lever as indicated.
Use in "Van" mode when filling a car could result in damage to the vehicle.

ATTENTION



The above functions apply to the models PRO AC and IBC AC only. In the DELPHIN PRO_X AC model the flow rate is regulated by the management system.

12.3 PHASES OF DELIVERY

- | | |
|---|--|
| 1 | Connect the connector to the tank by screwing it clockwise |
| 2 | Press POWER button A. |
| 3 | Press the REFILL button B for 3 seconds. |
| 4 | Wait for the filling end. |
| 5 | Disconnect the connector from the tank by unscrewing it counter-clockwise. |
| 6 | Place the connector in the appropriate housing by screwing it clockwise. |

ATTENTION



- DO NOT USE IF:**
- THE CONNECTOR IS NOT COMPLETELY CONNECTED TO THE CAR TANK
 - THE CONNECTOR IS NOT CONNECTED TO THE SAFETY HOOK.

13 SYSTEM CUSTOMIZATION

THIS CHAPTER, WITH ALL ITS PARAGRAPHS, REFERS TO THE “PRO” AND “PRO_IBC” MODELS. FOR THE FUNCTIONS OF THE PRO_X MODELS, SEE THE QUICK GUIDE MO495.

13.1 USERS BUTTONS

FOREWORD

The METER features two buttons (RESET and MODE/ENTER) which individually perform two main functions and, together, other secondary functions.

MAIN FUNCTIONS PERFORMED SECONDARY FUNCTIONS LEGEND

- for the RESET key, resetting the partial register and Reset Total
 - for the MODE/ENTER key, entering instrument calibration mode
 Used together, the two keys permit entering configuration mode where the desired unit of measurement can be set.

CALIBRATE MEANS PERFORMING ACTIONS ON THE METER KEYS. BELOW IS THE LEGEND OF THE SYMBOLS USED TO DESCRIBE THE ACTIONS TO BE PERFORMED

<p>BRIEF PRESS OF MODE/ENTER BUTTON</p> 	<p>LONG PRESS OF MODE/ENTER BUTTON</p> 	<p>BRIEF PRESS OF RESET BUTTON</p> 	<p>LONG PRESS OF RESET BUTTON</p> 
--	---	---	--

13.2 OPERATING MODES

OPERATING MODES

The user can choose between two different operating modes:
 The meter features a non-volatile memory for storing the dispensing data, even in the event of a complete power break for long periods.
 The measurement electronics and the LCD display are fitted in the top part of the measurement device which remains isolated from the fluid-bath measurement chamber and sealed from the outside by means of a cover.

- 1 - Normal Mode
- 2 - Flow rate Mode

Normal Mode: Mode with display of Partial and Total dispensed quantities
 Flow Rate Mode: Mode with display of Flow Rate, as well as Partial dispensed quantity.

13.3 DAILY USE

FOREWORD

The only operations that need to be done for daily use are partial and/or resettable total register resetting. The user should use only the dispensing system of measurement device. Occasionally the meter may need to be configured or calibrated. To do so, please refer to the relevant chapters.

Below are the two typical normal operation displays. One display page shows the partial and reset total registers. The other shows the partial and general total. Switchover from resettable total to general total display is automatic and tied to phases and times that are in factory set and cannot be changed.

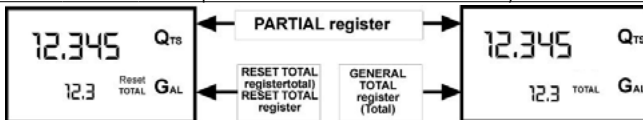

NOTE



6 digits are available for Totals, plus two icons x 10 / x100. The increment sequence is the following:
 0.0 -> 99999.9 -> 999999 -> 100000 x 10 -> 999999 x 10 -> 100000 x 100 -> 999999 x 100

13.4 DISPENSING IN NORMAL MODE

FOREWORD

Normal mode is the standard dispensing. While the count is made, the partial and resettable total are displayed at the same time (reset total).

WARNING



Should one of the keys be accidentally pressed during dispensing, this will have no effect.

STAND BY

A few seconds after dispensing has ended, on the lower register, the display switches from resettable total to general total: the word reset above the word total disappears, and the reset total is replaced by the general total.

This situation is called standby and remains stable until the user operates the measurement device again.

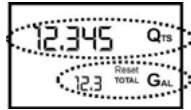

13.5 PARTIAL RESET (NORMAL MODE)

The partial register can be reset by pressing the reset key when the meter is in standby, meaning when the display screen shows the word "TOTAL".



After pressing the reset key, during reset, the display screen first of all shows all the lit-up digits and then all the digits that are not lit up.

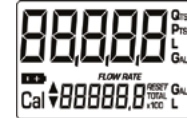

At the end of the process, a display page is first of all shown with the reset partial and the reset total.



and, after a few moments, the reset total is replaced by the non resettable Total.



13.6 RESETTING THE RESET TOTAL

The reset total resetting operation can only be performed after resetting the partial register. The reset total can in fact be reset by pressing the reset key at length while the display screen shows reset total as on the following display page:



Schematically, the steps to be taken are:

- 1 - Wait for the display to show normal standby display page (with total only displayed)
- 2 - Press the reset key quickly
- 3 - The meter starts to reset the partial
- 4 - While the display page showing the reset total is displayed Press the reset key again for at least 1 second



- 5 - The display screen again shows all the segments of the display followed by all the switched-off segments and finally shows the display page where the reset Reset Total is shown.



13.7 DISPENSING WITH FLOW RATE MODE DISPLAY

It is possible to dispense fluids, displaying at the same time::

- 1 the dispensed partial.
- 2 the Flow Rate in [Partial Unit / minute] as shown on the following display page:



Procedure for entering this mode:

- 1 wait for the Remote Display to go to Standby, meaning the display screen shows Total only
- 2 quickly press the MODE/ENTER key.
- 3 Start dispensing.

The flow rate is updated every 0.7 seconds. Consequently, the display could be relatively unstable at lower flow rates. The higher the flow rate, the more stable the displayed value.

ATTENTION



The flow rate is measured with reference to the unit of measurement of the Partial. For this reason, in case of the unit of measurement of the Partial and Total being different, as in the example shown below, it should be remembered that the indicated flow rate relates to the unit of measurement of the partial. In the example shown, the flow rate is expressed in Qts/min.



The word “Gal” remaining alongside the flow rate refers to the register of the Totals (Reset or NON Reset) which are again displayed when exiting from the flow rate reading mode.

To return to “Normal” mode, press the MODE/ENTER key again. If one of the two keys RESET or MODE/ENTER is accidentally pressed during the count, this will have no effect.

ATTENTION

Even though in this mode they are not displayed, both the Reset Total and the General Total (Total) increase. Their value can be checked after dispensing has terminated, returning to "Normal" mode, by quickly pressing MODE.

13.7.1 PARTIAL RESET (FLOW RATE MODE)

To reset the Partial Register, finish dispensing and wait for the Remote Display to show a Flow Rate of O.O as indicated in the illustration

then quickly press RESET.

**13.8 CALIBRATION**

When operating close to extreme use or flow rate conditions (close to minimum or maximum acceptable values), an on-the-spot calibration may be required to suit the real conditions in which the measurement device is required to operate.

13.8.1 DEFINITIONS**CALIBRATION FACTOR OR "K FACTOR" FACTORY K FACTOR**

Multiplication factor applied by the system to the electrical pulses received, to transform these into measured fluid units.

Factory-set default factor. It is equal to 1,000. This calibration factor ensures utmost precision in the following operating conditions:

Fluid water/urea solution
Temperature: 20°C
Flow rate: 7 ltr/min

Even after any changes have been made by the user, the factory k factor can be restored by means of a simple procedure.

USER K FACTOR:

Customized calibration factor, meaning modified by calibration.

13.8.2 CALIBRATION MODE

Why calibrate?	1	Display the currently used calibration factor:
	2	Return to factory calibration (Factory K Factor) after a previous calibration by the user
	3	Change the calibration factor using one of the two previously indicated procedures

FOREWORD	Two procedures are available for changing the Calibration Factor:	
	1	In-Field Calibration, performed by means of a dispensing operation
	2	Direct Calibration, performed by directly changing the calibration factor

In calibration mode, the partial and total dispensed quantities indicated on the display screen take on different meanings according to the calibration procedure phase. In calibration mode, the measurement device cannot be used for normal dispensing operations. In "Calibration" mode, the totals are not increased

ATTENTION



The Measurement device features a non-volatile memory that keeps the data concerning calibration and total dispensed quantity stored for an indefinite time, even in the case of a long power break; after changing the batteries, calibration need not be repeated.

13.8.3 DISPLAY AND RESTORING K-FACTOR



By pressing the MODE/ENTER key while the appliance is in Standby, the display page appears showing the current calibration factor used. If no calibration has ever been performed, or the factory setting has been restored after previous calibrations, the following display page will appear:



The word "Fact" abbreviation for "factory" shows that the factory calibration factor is being used

If, on the other hand, calibrations have been made by the user, the display page will appear showing the currently used calibration factor (in our example 0,998). The word "user" indicates a calibration factor set by the user is being used..





The flow chart alongside shows the switchover logic from one display page to another

In this condition, the Reset key permits switching from User factor to Factory factor. To confirm the choice of calibration factor, quickly press MODE/ENTER while "User" or "Fact" are displayed. After the restart cycle, the Measurement device uses the calibration factor that has just been confirmed

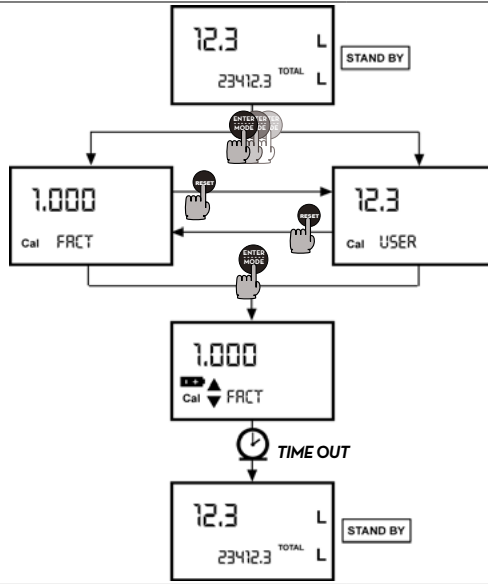

ATTENTION



When the Factory Factor is confirmed, the old User factor is deleted from the memory

13.8.4 DIRECT MODIFICATION OF K-FACTOR

If normal Meter operation shows a mean percentage error, this can be corrected by applying to the currently used calibration factor a correction of the same percentage. In this case, the percentage correction of the USER K FACTOR must be calculated by the operator in the following way

$$\text{New Cal. Factor} = \text{Old Cal. Factor} * (100 - E\% / 100)$$















EXAMPLE:

Error percentage found: E% - 0.9 %

CURRENT calibration factor: 1.000

New USER K FACTOR: $1.000 * [(100 - (-0.9))/100] = 1.000 * [(100 + 0.9)/100] = 1.009$

If the Meter indicates less than the real dispensed value (negative error) the new calibration factor must be higher than the old one as shown in the example. The opposite applies if the Meter shows more than the real dispensed value (positive error).

ACTION		DISPLAY
1	<p>NONE METER in Standby.</p>	
2	 <p>LONG MODE/ENTER KEY KEYING Meter enters calibration mode, shows “MODE” and displays the calibration factor being used instead of the partial. The words “Fact” and “User” indicate which of the two factors (factory or user) is currently being used.</p>	
3	 <p>LONG RESET KEY KEYING The Meter shows “MODE” and the zero partial total. Meter is ready to perform in-field calibration by dispensing – see previous paragraph.</p>	
4	 <p>LONG RESET KEY KEYING We now go on to Direct change of the calibration factor: the word “Direct” appears together with the Currently Used calibration factor. In the bottom left part of the display, an arrow appears (upwards or downwards) defining the direction (increase or decrease) of change of the displayed value when subsequent operations 5 or 6 are performed.</p>	
5	 <p>SHORT RESET KEY KEYING Changes the direction of the arrow. The operation can be repeated to alternate the direction of the arrow.</p>	
6	 <p>SHORT/LONG MODE/ENTER KEY KEYING The indicated value changes in the direction indicated by the arrow - one unit for every short MODE/ENTER key keying - continually if the MODE/ENTER key is kept pressed. The speed increase rises by keeping the key pressed. If the desired value is exceeded, repeat the operations from point (5).</p>	
7	 <p>LONG RESET KEY KEYING The Meter is informed that the calibration procedure is finished. Before performing this operation, make sure the INDICATED value is that required.</p>	
8	<p>NO OPERATION At the end of the calculation, the new USER K FACTOR is shown for a few seconds, after which the restart cycle is repeated to finally achieve standby condition. IMPORTANT: From now on, the indicated factor will become the calibration factor used by the Meter and will continue to remain such even after a battery change</p>	
9	<p>NO OPERATION The Meter stores the new work calibration factor and is ready to begin dispensing, using the USER K FACTOR that has just been changed.</p>	

13.9 METER CONFIGURATION

The METER feature a menu with which the user can select the main measurement unit, Quarts (Qts), Pints (Pts), Litres (Lit), Gallons (Gal); The combination of the unit of measurement of the Partial register and that of the Totals is predefined according to the following table:

Combination no.	Unit of Measurement Partial Register	Unit of Measurement Totals Register
1	Litres (L)	Litres (L)
2	Gallons (Gal)	Gallons (Gal)
3	Quarts (Qts)	Gallons (Gal)
4	Pints (Pts)	Gallons (Gal)

To choose between the 4 available combinations:

1

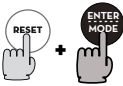

Wait for the METER to go to Standby

Then press the MODE and RESET keys together. Keep these pressed until the word "UNIT" appears on the screen together with the unit of measurement set at that time (in this example Litres / Litres)

2



Every short press of the RESET key, the various combinations of the units of measurements are scrolled as shown below:

3

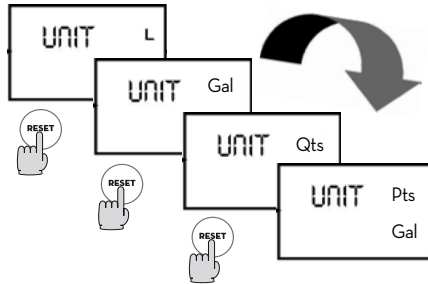

4



ATTENTION

By pressing the MODE key at length, the new settings will be stored, the METER will pass through the start cycle and will then be ready to dispense in the set units.



The Reset Total and Total registers will be automatically changed to the new unit of measurement.
NO new calibration is required after changing the Unit of Measurement.

14 LEAVING THE SYSTEM UNUSED FOR LONG PERIODS OF TIME

Operations to be carried out

Whenever it is thought that the system will remain unused for at least 15 days, it must be emptied in order to prevent the product from crystallising inside. This shall be followed by a washing cycle.

15 WASHING THE DISPENSING SYSTEM

WHY TO WASH ATTENTION



The dispensing system requires washing in order to remove product crystallisation which may damage the plant.

Wear personal protective equipment (PPE) when performing the wash cycle. Use only demineralised water to wash the system.

PHASES OF DELIVERY FOR CLEANING

Following the same dispensing methods previously described (12.3 - DISPENSING PHASES), wash the distribution system by aspirating about 20 liters of demineralized water from a clean container and collecting the resulting mixture in a different container, suitable for disposal.

1 - Press POWER button A.

2 - Press the REFILL button B for 3 seconds.

3 - Wait for the filling end.

4 - Place the connector in the appropriate housing by screwing it clockwise.

Disposal ATTENTION



By following the same modes of delivery described above, the dispensing system can be washed by sucking up demineralised water from the clean container and collecting the resulting mixture in a different disposable container.

Liquids resulting from washing must be disposed of in accordance with the laws prevailing in the country of use.

16 MAINTENANCE

Safety warnings

The distribution system has been designed and built to require minimum maintenance.

Before carrying out any maintenance work, disconnect the dispensing system from any electrical and hydraulic power source.

During maintenance procedures, using personal protection equipment (PPE) is mandatory.

Always consider the following recommendations to use the pump correctly.

Personnel authorised to perform maintenance procedures Interventions to be performed

Maintenance procedures must be performed exclusively by qualified personnel. Any misuse may lead to a decline in performance, danger for people and/or things, besides voiding the warranty.

Whenever there is risk of frost, empty the circuit and the pump, taking care to place the pump in an environment where the temperature is no lower than 0°C/32°F. Check that the labels and plates found on the dispensing system do not deteriorate or become detached over time.

ONCE A WEEK

- Check that the pipe connections are not loose to prevent any leaks

- **Keep the parts free from obstructions due to dirt or crystallization:**

1 - n° 2 END OF FILLING sensors: these are used to stop product delivery.

2 - DRIP-STOP VALVE: prevents spills and dripping.



ONCE A MONTH

- Check the pump body and keep it clean and free of any impurities

- Check that the electrical supply cables are in good condition

17 TROUBLESHOOTING

TROUBLE	POSSIBLE CAUSE	CORRECTIVE ACTION
The machine does not start. The display and the ON/OFF LED do not switch on.	AC versions: 1. Plug in the socket (no voltage / main switch possibly disconnected)	AC versions: Check main switch. If the problem persists, contact PIUSI customer Service.
	DC versions (Battery only supply): 1. Main switch disconnected. 2. Possible fuse breakage	DC versions (Battery only supply): 1. Connect the main switch 2. If the problem persists, battery cable fuse is broken (replace the fuse).
	DC versions (Power supply voltage and main switch disconnected) Plug in the socket (no voltage)	DC versions (Power supply voltage and switch disconnected) Contact PIUSI customer Service.
The machine switches on, but the pump does not run when "START" is pressed (PRO_X alarm LED)	Damaged pump	Contact PIUSI customer Service
	Melted fuse in the panel card (AC and DC versions)	
	DC version: battery run down	Connect to the mains to charge the battery. Dispensing is possible
Low flow rate (high filling time)	Storage at too low room temperature. Frozen Ad-Blue®.	Damaged pump, contact PIUSI customer Service
	Flow setting at min. value	Adjust the trimmer (if present) on "max.".
	Squeezed intake hose	Check the conditions of the intake hose. Adjust or replace
	Connections not tight	Check all the visible external connections and restore sealing wherever required
The spout sensor triggers continuously making dispensing impossible. PRO_X version: the status LED flashes 2 times	Squeezed delivery hose	Replace or restore the hose.
	Dirty spout sensors	Clean the spout under running water.
	Too high dispensing flow rate	Adjust the trimmer or the knob on lower flow rates or move the knob to "AUTO FLOW" (on PRO_X version only).
	Damaged sensor	Replace the delivery pipe
	Oxidized internal connection	
	The tank is full	Check the level in the tank



The spout sensor does not trigger with full tank	Low conductivity of the liquid	Check the technical specifications of the manufacturer of the AdBlue® in use
	Dirty spout sensors	Clean the spout under running water removing possible dirt covering the sensor.
	Loosened or disconnected electrode connections	Disassemble the panel and check
AdBlue®leaks	Loosened connections	Check and restore loosened hoses and joints
Difficult to move	Brake possibly applied on the front wheel	Release the brake on the front wheel

Technical Customer care Service:
 Piusi S.p.A. - tel. 0039 0376 234561
 e-mail: customercare@piusi.com

18 SCRAPPING AND DISPOSAL

Foreword

If the system needs to be disposed, the parts which make it up must be delivered to companies that specialize in the recycling and disposal of industrial waste and, in particular:

Disposing of packing materials

The packaging consists of biodegradable cardboard which can be delivered to companies for normal recycling of cellulose.

Metal Parts Disposal

Metal parts, whether paint-finished or in stainless steel, can be consigned to scrap metal collectors.

Disposal of electric and electronic components

These must be disposed of by companies that specialize in the disposal of electronic components, in accordance with the indications of directive 2012/19/UE (see text of directive below).



European Directive 2012/19/UE requires that all equipment marked with this symbol on the product and/or packaging not be disposed of together with non-differentiated urban waste. The symbol indicates that this product must not be disposed of together with normal household waste. It is the responsibility of the owner to dispose of these products as well as other electric or electronic equipment by means of the specific refuse collection structures indicated by the government or the local governing authorities.

Information regarding the environment for clients residing within the European Union

Disposing of RAEE equipment as household wastes is strictly forbidden. Such wastes must be disposed of separately.

Any hazardous substances in the electrical and electronic appliances and/or the misuse of such appliances can have potentially serious consequences for the environment and human health.

In case of the unlawful disposal of said wastes, fines will be applicable as defined by the laws in force.

Miscellaneous parts disposal

Other components, such as pipes, rubber gaskets, plastic parts and wires, must be disposed of by companies specialising in the disposal of industrial waste.



© PIUSI S.p.A.

EN. This document has been drawn up with the greatest attention to precision and accuracy of all data herein contained. Nevertheless, PIUSI S.p.A. denies liability for any possible mistake or omission.



*Fluid Handling
Innovation*

Download the manual in your language!



piusi.com
PIUSI SpA • Suzzara MN Italy

<http://www.piusi.com/manual-delphin-pro-pro-x-ibc>

BULLETIN MO502A EN _00

03.2019